

ALM-1222

1.8-2.2GHz Low Noise, High Gain, High Linearity Balanced Amplifier Module



Data Sheet

Description

Avago Technologies' ALM-1222 is a very low noise, high linearity balanced amplifier module operating in the 1.8 to 2.2GHz frequency range. The exceptional noise and linearity performances are achieved through the use of Avago Technologies' proprietary 0.5um GaAs Enhancement-mode pHEMT process.

All matching components are fully integrated within the module and the 50Ω RF input and output pins are already internally AC-coupled. This makes the ALM-1222 extremely easy to use as the only external parts are DC supply bypass capacitors.

The ALM-1222 is housed in a miniature 5.0 x 6.0 x 1.1 mm³ 22-lead multiple-chips-on-board (MCOB) module package. The compact footprint and low profile makes this product an ideal choice for Wireless Infrastructure Basestation Tower-Mounted Amplifiers (TMA), Radiocards and Multi-Carrier Driver Amplifiers in the cellular/PCS/CDMA bands.

Component Image

5.0 x 6.0 x 1.1 mm³ 22-lead MCOB

Top View

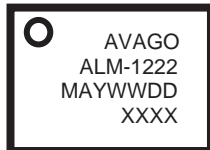

Note:
Package marking provides orientation and identification
"ALM-1222" = Device Part Number
"YWWDD" = Year, work week and day of manufacture
"XXXX" = Assembly lot number

Bottom View

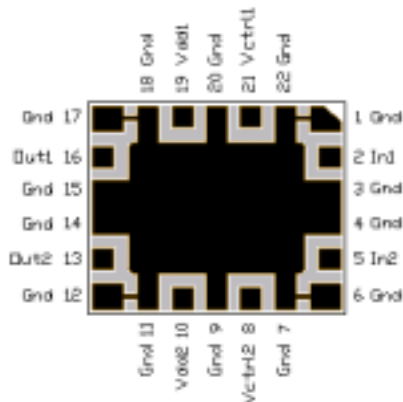

Features

- Low noise figure
- High linearity and P1dB
- GaAs E-pHEMT Technology^[1]
- 50Ω internal matching
- Small package size: 5x6x1.1 mm³
- 5V supply
- Adjustable current for optimum NF or OIP3
- Excellent uniformity in product specifications
- Tape-and-Reel packaging option available
- MSL-2a and Lead-free
- Point MTTF > 300 years at 120°C channel temperature
- Shutdown function
- Specifications
 - 2GHz; 5V, 280mA (typ) per section
 - Vctrl typically at 2.3V
 - 31 dB Gain
 - 0.62 dB Noise Figure
 - 43.7 dBm Output IP3
 - 27.5 dBm Output Power at 1dB gain compression
 - 45dB Reverse Isolation

Applications

- Diversity Antenna, TMA & Front End LNA for EGSM/PCS/W-CDMA Base Stations.
- Driver amplifier.

Notes:

1. Enhancement mode technology employs positive gate voltage, thereby eliminating the need of negative gate voltage associated with conventional depletion mode devices.



Attention: Observe precautions for handling electrostatic sensitive devices.
ESD Machine Model = 50 V
ESD Human Body Model = 250 V
Refer to Avago Technologies Application Note A004R: *Electrostatic Discharge, Damage and Control.*

Absolute Maximum Rating ^[2] T_A=25°C

Symbol	Parameter	Units	Absolute Max.
V _{dd}	Device Voltage, RF output to ground	V	5.5
V _{ctrl}	Control Voltage	V	3.0
P _{in,max}	CW RF Input Power (V _{dd} = 5.0, I _{dd} =280mA)	dBm	22
P _{diss}	Total Power Dissipation ^[4]	W	5
T _j	Junction Temperature	°C	150
T _{STG}	Storage Temperature	°C	-65 to 150

Thermal Resistance ^[3]
(V_{dd} = 5.0V, V_{ctrl}=2.2V)
θ_{jc} = 20 °C/W

Notes:

- Operation of this device in excess of any of these limits may cause permanent damage.
- Thermal resistance measured using Infra-Red measurement technique.
- Board (module belly) temperature T_B is 25 °C. Derate 50mW/°C for T_B>95 °C.

Product Consistency Distribution Charts ^[5,6]

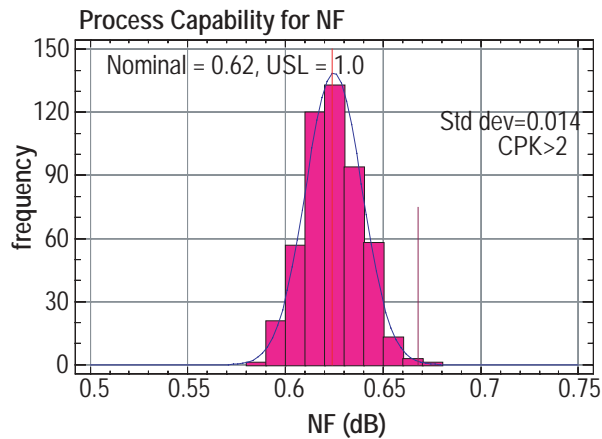

Figure 1. NF@ 2.0GHz; 5V, 280mA

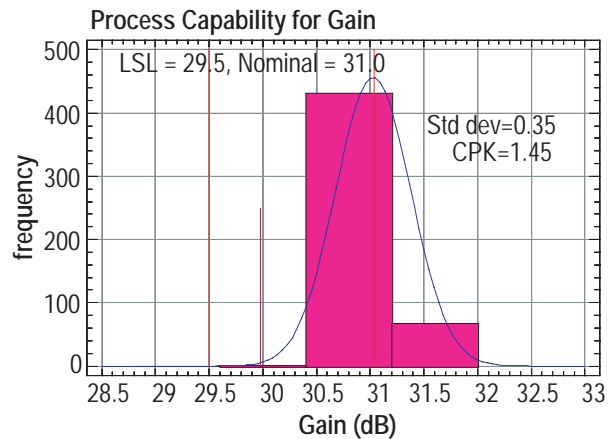

Figure 2. Gain @ 2.0GHz; 5V, 280mA

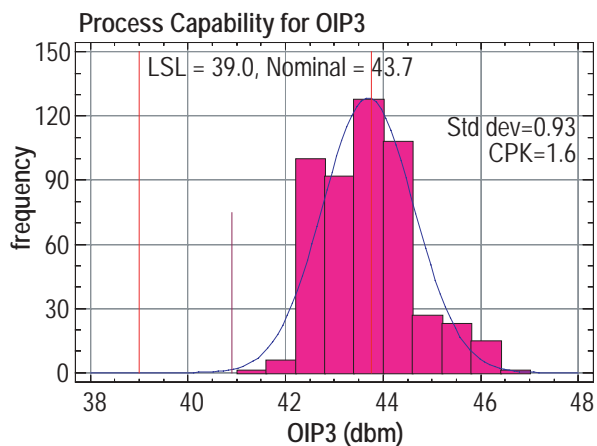

Figure 3. OIP3@ 2.0GHz; 5V, 280mA

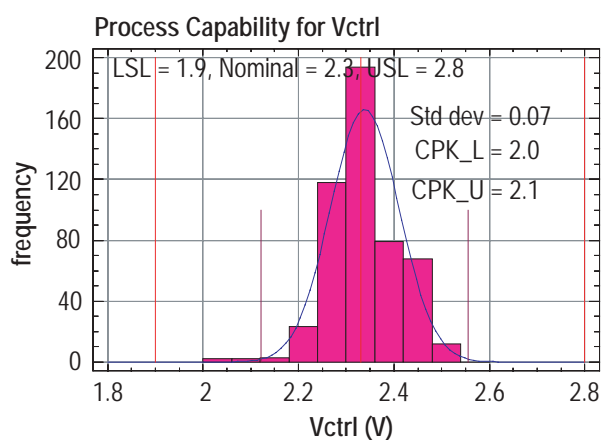

Figure 4. V_{ctrl} @ 2.0GHz; 5V, 280mA

Note:

- Distribution data sample size is 500 samples taken from 3 different wafers and 3 different lots. Future wafers allocated to this product may have nominal values anywhere between the upper and lower limits.
- Measurements are made on a production test board, which can show a variance of up to 1dB in gain and OIP3 compared to a soldered-down demo board. Input trace losses have been de-embedded from actual measurements.

Electrical Specifications [7], [10]

$T_A = 25\text{ }^\circ\text{C}$, $V_{dd} = 5\text{V}$ @ 280mA , RF performance at 2.0 GHz, given for each of the 2 RF paths, measured on demo board (see Fig. 5) unless otherwise specified.

Symbol	Parameter and Test Condition	Units	Min.	Typ.	Max.
Vctrl	Control Voltage, $I_{dd}=280\text{mA}$		1.9	2.3	2.8
Gain	Gain	dB	29.5	31	32.5
OIP3 [8]	Output Third Order Intercept Point	dBm	39	43.7	-
NF [9]	Noise Figure (Typ.Vctrl=2.2V)	dB	-	0.62	1.00
OP1dB	Output Power at 1dB Gain Compression	dBm	-	27.5	-
S11	Input Return Loss, 50Ω source	dB	-	-8	-
S22	Output Return Loss, 50Ω load	dB	-	-10	-
S12	Reverse Isolation	dB	-	45	-
ISO _{1,2}	Isolation between RF Input 1 and RF Input 2	dB	-	22	-

Notes:

- Measurements at 2GHz obtained using demo board described in Fig 5.
- 2GHz OIP3 test condition: $F_{RF1} = 2.0\text{ GHz}$, $F_{RF2} = 2.01\text{ GHz}$ with input power of -20dBm per tone measured at lower side band.
- For NF data, board losses of 0.12dB at the input have been de-embedded.
- Use proper bias, heatsink and derating to ensure maximum channel temperature is not exceeded. See absolute maximum ratings and application note for more details.

Demo Board Layout

Circuit Symbol	Size	Description
C1, C10	0805	2.2uF ceramic
C2, C7	0402	Not used
C3, C6	0402	0.1uF ceramic
C4, C9	0402	Not used
C5, C8	0402	0.1uF ceramic

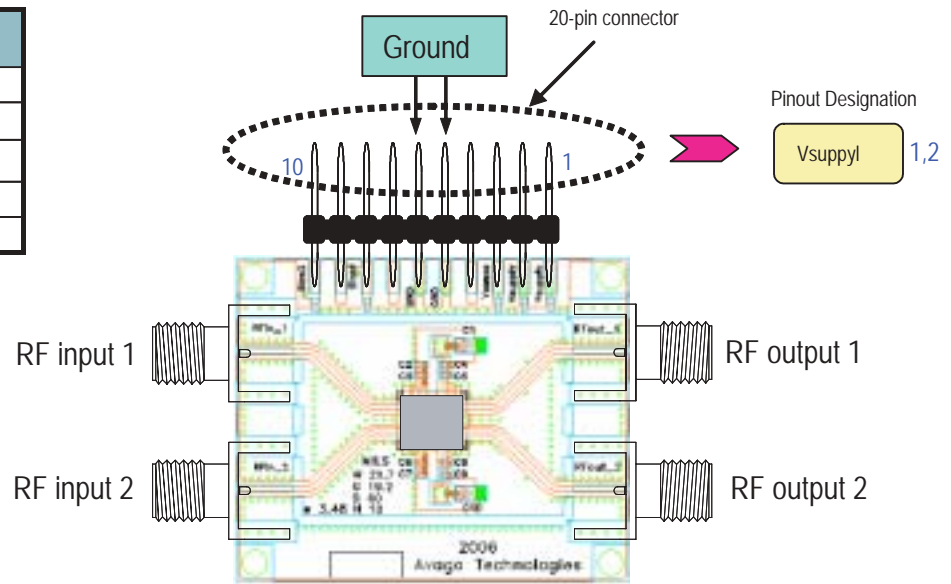

Figure 5. Demo Board Layout Diagram

Recommended PCB material is 10 mils Rogers RO4350.

Suggested component values may vary according to layout and PCB material.

Demo Board Schematic

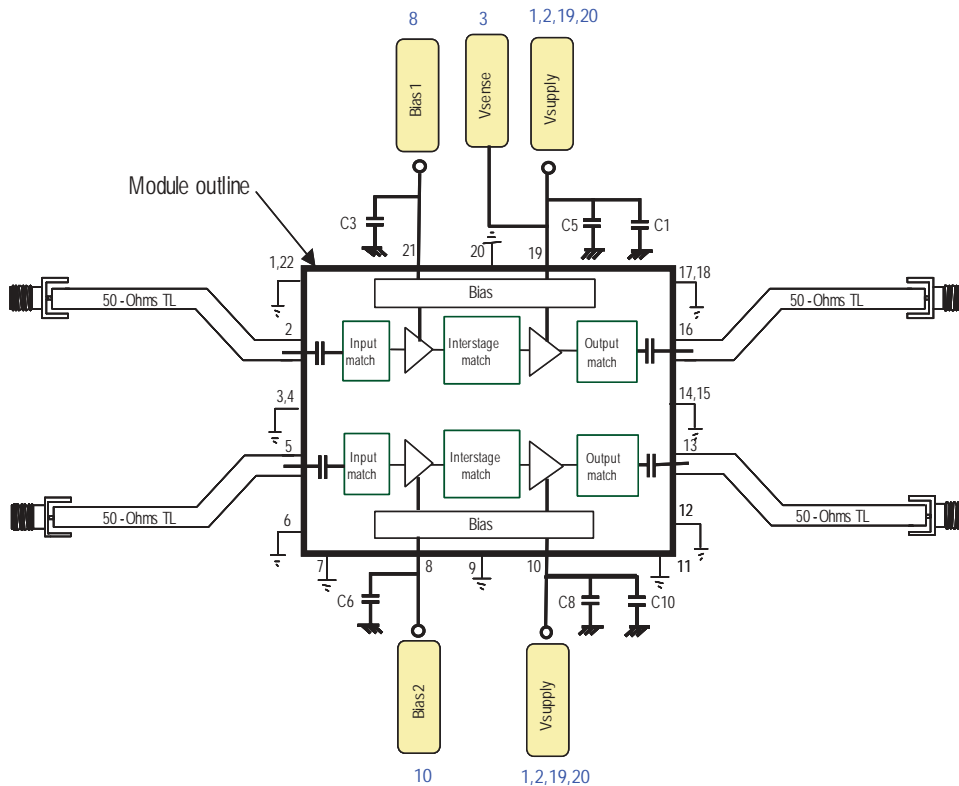

Figure 6. Demo Board Schematic Diagram

Balanced Amplifier Demo Board Layout

Circuit Symbol	Size	Description
C1, C10	0805	2.2uF ceramic
C2, C7	0402	Not used
C3, C6	0402	0.1uF ceramic
C4, C9	0402	Not used
C5, C8	0402	0.1uF ceramic
R1, R4	0402	Not used
R2, R3	0402	49.9 ohms
Coupler	14.22x5.08 mm ²	Anaren Xinger II XC1900E-03 or equiv

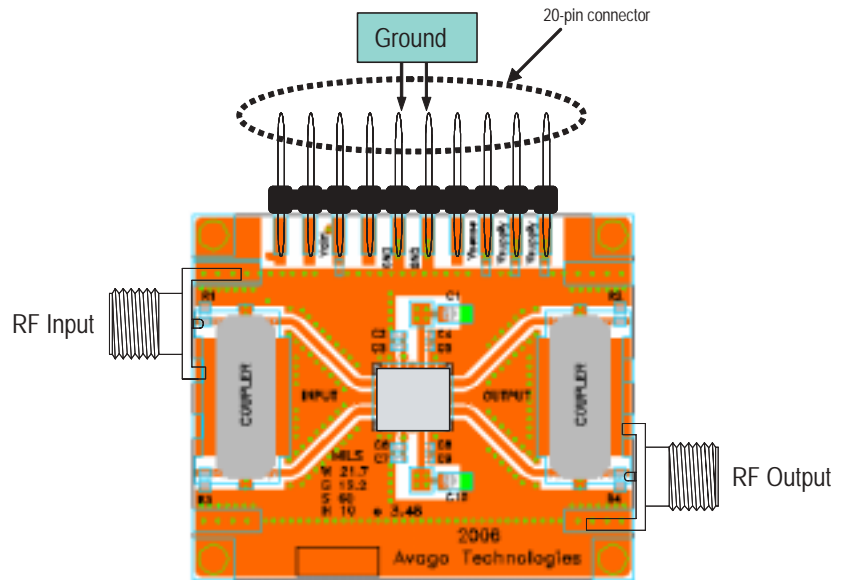

Figure 7. Suggested Balanced Amplifier Demo Board Layout

Recommended PCB material is 10 mils Rogers RO4350.

Suggested component values may vary according to layout and PCB material.

Balanced Demo Board Schematic

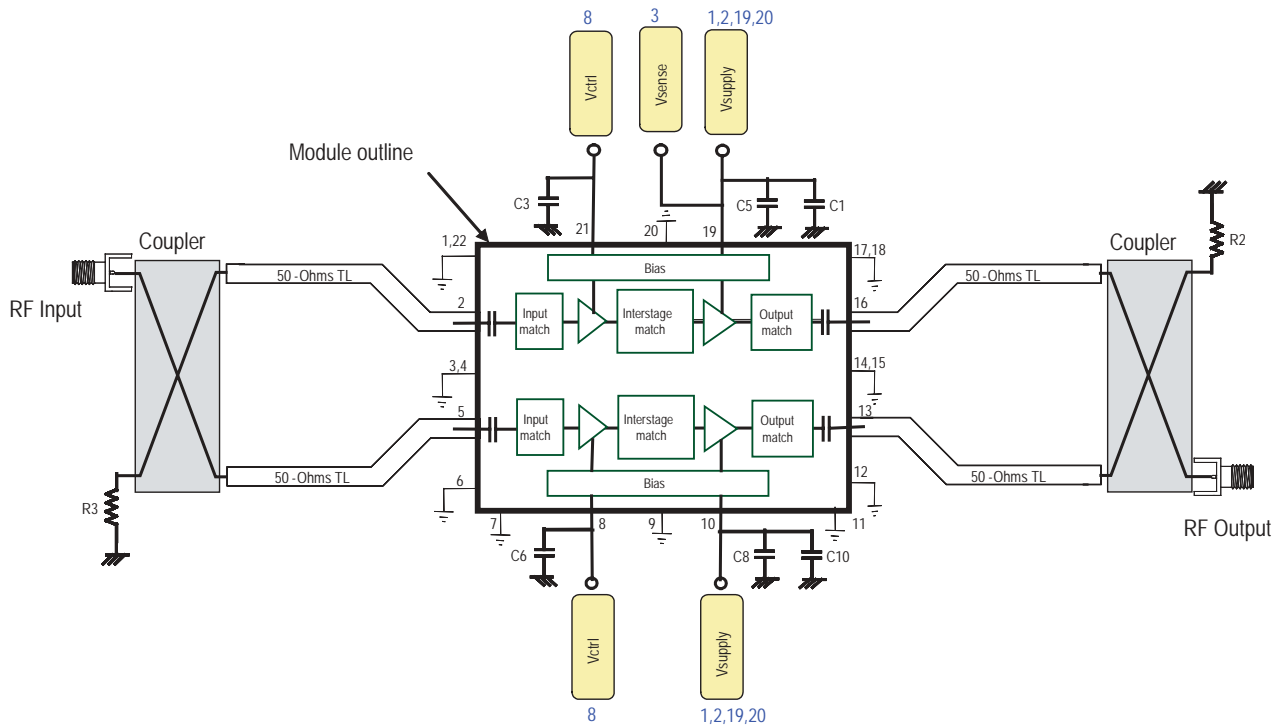

Figure 8. Application Schematic for Balanced Amplifier

ALM-1222 Typical Performance I

$T_A = +25\text{ }^\circ\text{C}$, $V_{dd} = 5\text{V}$, $I_{dd} = 280\text{mA}$ Input Signal=CW unless stated otherwise.

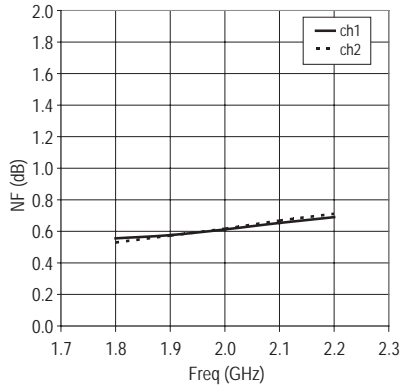

Figure 9. NF vs Frequency and channel

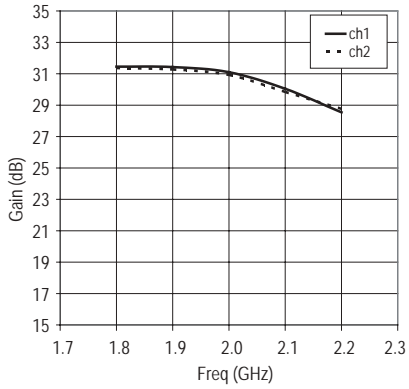

Figure 10. Gain vs Frequency and channel

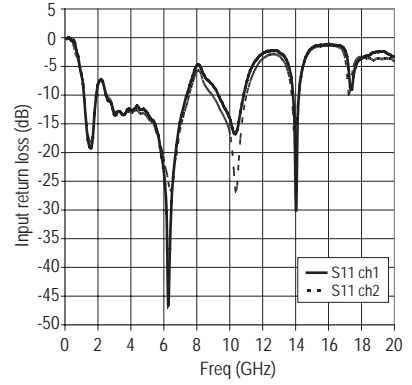

Figure 11. S11 vs Frequency and channel

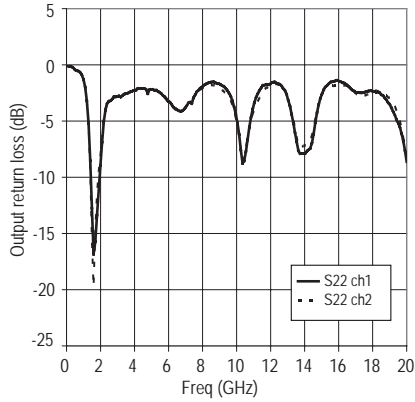

Figure 12. S22 vs Frequency and channel

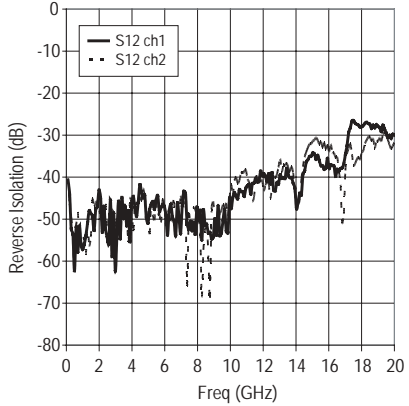

Figure 13. Isolation vs Frequency and channel

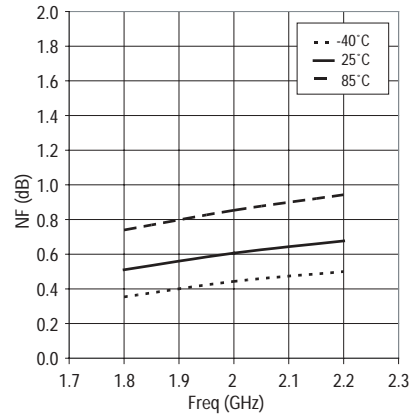

Figure 14. NF vs Frequency and temperature

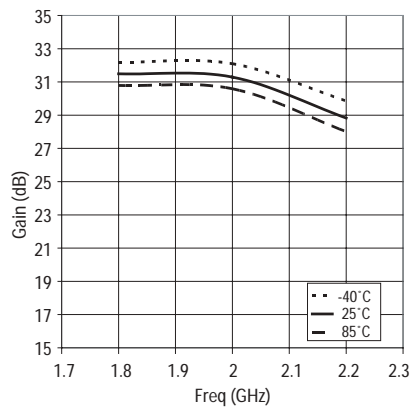

Figure 15. Gain vs Frequency and temperature

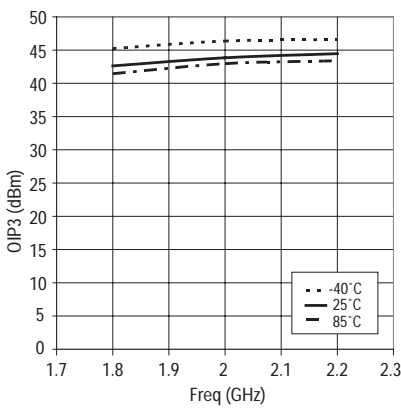

Figure 16. OIP3 vs Frequency and temperature

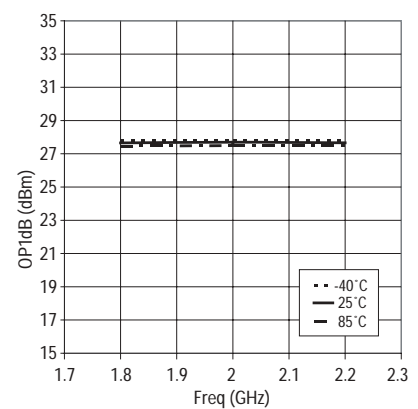

Figure 17. OP1dB vs Frequency and temperature

ALM-1222 Typical Performance II

$T_A = +25\text{ }^\circ\text{C}$, $V_{dd} = 5\text{V}$, $I_{dd} = 280\text{mA}$, Frequency = 2GHz. Input Signal=CW unless stated otherwise.

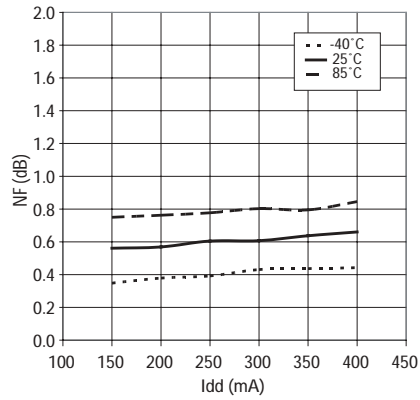

Figure 18. NF vs Idd and temperature

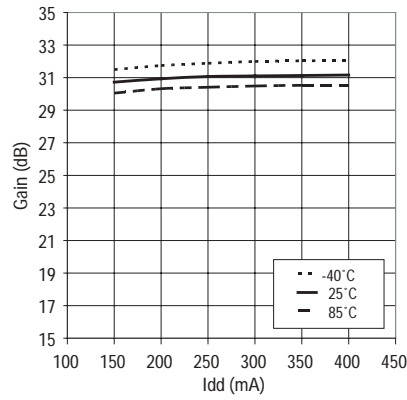

Figure 19. Gain vs Idd and temperature

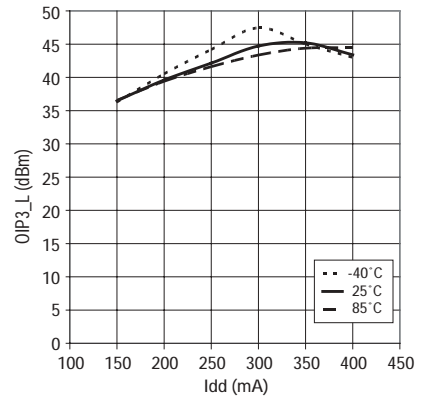

Figure 20. OIP3 vs Idd and temperature

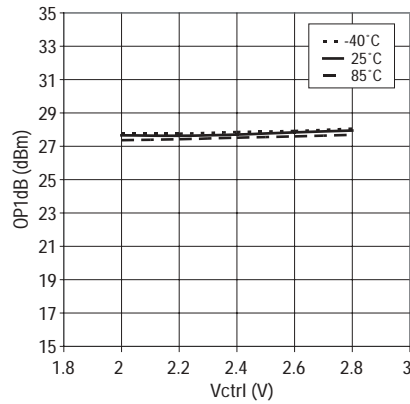

Figure 21. OP1dB vs Vctrl and temperature

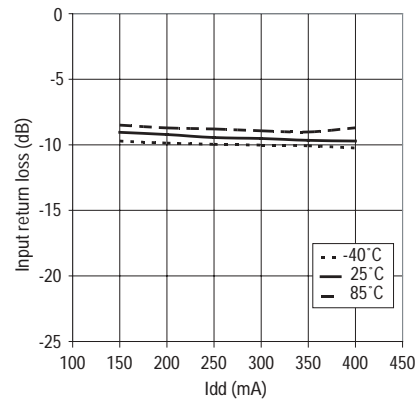

Figure 22. S11 vs Idd and temperature

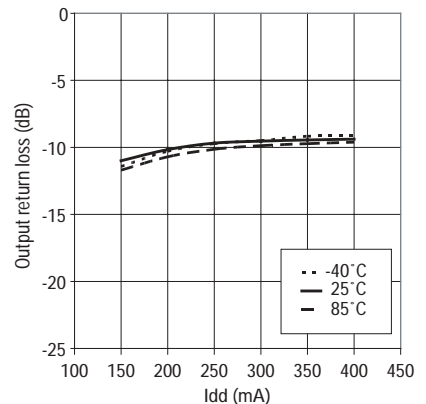

Figure 23. S22 vs Idd and temperature

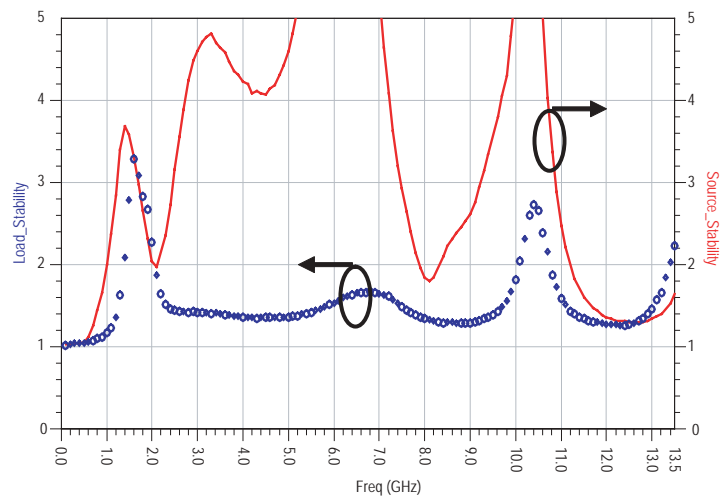
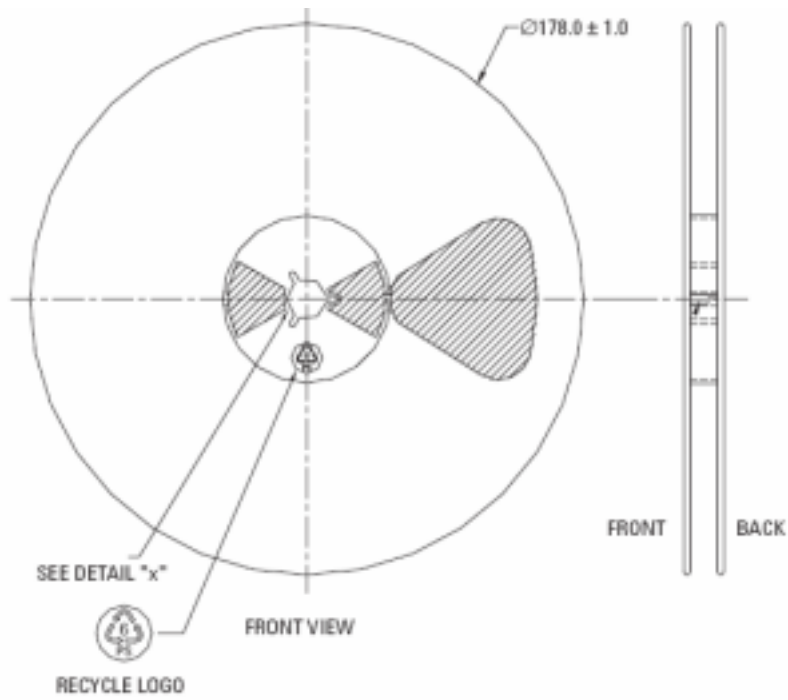

Figure 24. Stability over frequency

Reel Dimensions



Part Number Ordering Information

Part Number	No. of Devices	Container
ALM-1222-BLKG	100	Antistatic bag
ALM-1222-TR1G	1000	7" Reel
ALM-1222-TR2G	3000	13" Reel

For product information and a complete list of distributors, please go to our web site: www.avagotech.com

Avago, Avago Technologies, and the A logo are trademarks of Avago Technologies, Pte. in the United States and other countries.
Data subject to change. Copyright © 2006 Avago Technologies Pte. All rights reserved.

AV01-0058EN - June 15, 2006

